

# MECBO



## AUT 42

### TRUCK MOUNTED PUMP

Truck	4 axles
Distributor boom	M42.5/125-XZ
Pumping group	P6 / P7 / P8

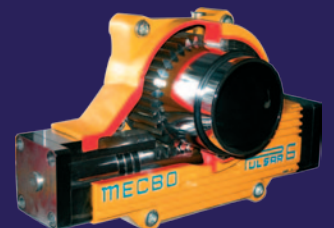

**PULSAR SYSTEM**

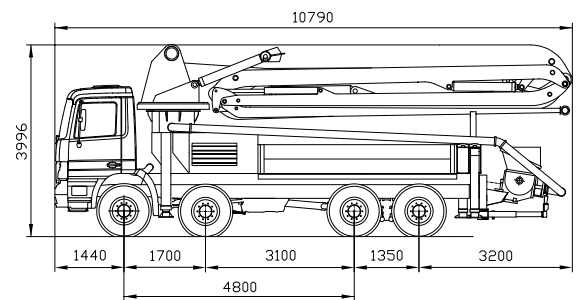
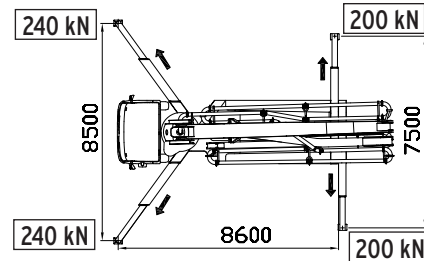
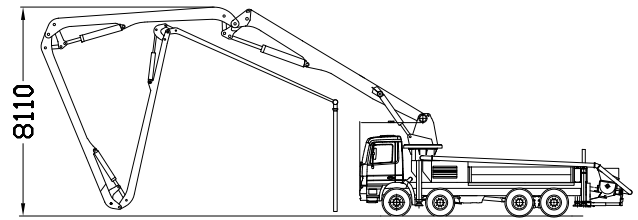
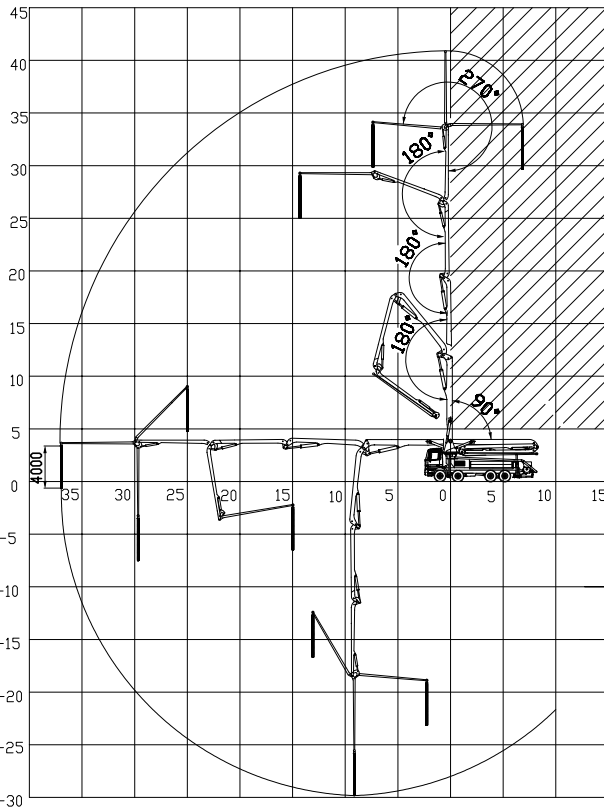

BRACCIO DISTRIBUTORE DISTRIBUTOR BOOM FLECHE DISTRIBUTEUR VERTEILERMAST		GRUPPO POMPANTE PUMPING GROUP GROUPE DE POMPAGE PUMPENGRUPPE			
Diametro tubazione Pipeline diameter Diamètre de la tuyauterie Förderleitung Durchmesser	<b>125 mm</b>	Pompa tipo Pump type Pompe type Pumpeart	<b>P6.110</b>	<b>P7.150</b>	<b>P8.180</b>
Raggio orizzontale Horizontal reach Portée horizontale Horizontalablenkung	<b>38 m</b>	Diametro dei cilindri Cylinders diameter Diamètre cylindres Zylindersdurchmesser	<b>200 mm</b>	<b>230 mm</b>	<b>250 mm</b>
Altezza massima Max. vertical reach Portée verticale Max. Höhe	<b>42 m</b>	Corsa Stroke Course Schlagenfall	<b>2000 mm</b>	<b>2000 mm</b>	<b>2000 mm</b>
Min. altezza apertura Min. openig height Min. hauteur d'ouverture Min. Öffnungshöhe	<b>8,1 m</b>	Diametro uscita Outlet diameter Diamètre sortie Austrittsdurchmesser	<b>150 mm (6" 1/2)</b>	<b>150 mm (6" 1/2)</b>	<b>180 mm (7" 1/2)</b>
Numero di sezioni Sections Number Nombre de sections Anzahl der Abschnitte	<b>5 ZR</b>	Volume tramoggia Hopper capacity Capacité trémie Kapazität des Trichters	<b>620 l</b>	<b>600 l</b>	<b>610 l</b>
Rotazione torretta Slewing range Rotation de la tourelle Turmdrehung	<b>370°</b>	Pressione in uscita Outlet pressure Pression sortie Betondruck	<b>70 bar</b>	<b>70 bar</b>	<b>70 bar</b>
Pressione oleodinamica Hydraulic pressure Pression hydraulique Hydraulikdruck	<b>350 bar</b>	Portata calcestruzzo Concrete output Débit béton Beton Fördermenge	<b>110 m³/h</b>	<b>150 m³/h</b>	<b>180 m³/h</b>
Tensione imp. Elettrico Electrical voltage Tension électrique Spannung des Elektr.System	<b>12-24V</b>	Peso gruppo pompante Pumping Group weight Poids groupe pompage Pumpegewicht	<b>1950 kg</b>	<b>2300 kg</b>	<b>2500 kg</b>
<p>Inclusi nella fornitura doppio circuito idraulico, pompa acqua, serbatoio, acqua, compressore, telecomando, radiocomando, sistema di stabilità "Full Range" (EN 12001:2012). Supplied with double hydraulic circuit, water pump and tank, air compressor, remote control by cable, wireless radio control, stability system "Full Range" (EN 12001:2012). Inclus double circuit hydraulique, pompe à eau, réservoir eau, compresseur, télécommande, radiocommande, système de stabilité "Full Range" (EN 12001:2012). Inbegriffen doppelt Hydraulikschaltung, Wasserpumpe, Wassertank, Kompressor, Kabel-Fernbedienung, Radio-Fernbedienung, Stabilitätssystem "Full Range" (EN 12001:2012).</p>					



OPTIONAL - EN OPTION - FAKULTATIV

VIBRATORE - VIBRATOR  
VIBRATEUR - VIBRATOR

SISTEMA STABILITA' "SINGLE SIDE RANGE" (EN 12001:2012)  
STABILITY SYSTEM "SINGLE SIDE RANGE" (EN 12001:2012)  
SYSTEME DE STABILITE' "SINGLE SIDE RANGE" (EN 12001:2012)  
STABILITÄTSSYSTEM "SINGLE SIDE RANGE" (EN 12001:2012)

TUBAZIONE E ACCESSORI  
PIPELINES AND ACCESSORIES  
TUYAUTERIES ET ACCESSOIRES  
ROHRLEITUNG UND ZUBEHÖRE

LUBRIFICAZIONE AUTOMATICA  
LINCOLN  
LINCOLN AUTOMATIC LUBRICATION  
LUBRIFICATION AUTOMATIQUE  
LINCOLN  
AUTOMATISCHE SCHMIERUNG

I presenti dati tecnici hanno valore indicativo. Con l'evolversi della tecnologia, i dati esposti potranno subire modifiche senza preavviso. Le richieste tecniche specifiche debbono essere sempre accettate dalla nostra Direzione con conferma scritta. The present technical data have indicative value. Owing to the technology development, all above mentioned details may be changed without any notice. All specific technical request must be always accepted from our Management by written confirmation.